

Manufacturer	Phoenix Ovens, Australia	
Model No.	Tandoor TS850E	
Description	Tandoor Oven – Square Stainless Steel exterior finish Superior thermal ceramic coated steel inner drum (<i>cooking surface is ceramic</i>)	
Purpose	Indian Tandoor oven for cooking naan breads, skewered meats and other dishes	
Energy Type	Electric	
Electric Requirements	ELECTRIC: 3 Phase with Neutral, 11kW	
Exhaust Requirements	Under Exhaust Canopy/Hood (by others)	
External Dims	850mm Diameter x 900mm (H) <i>includes adjustable legs</i>	Weight (Approx.): 500kg
Internal Dims	530mm Diameter	
Warranty	4 Year Structural, 12 Months for Electric System & Components	
Safety Notes	The oven must be vented in accordance with local and/or national codes	
Manufacturer Materials	Durable high quality ceramic cooking surface, structurally reinforced for longevity and durability. Materials fully insulated and housed in stainless steel external finish.	

STANDARD FEATURES & OPTIONS

- Durable hi temp ceramic coated cooking surface with steel inner bowl for superior heat transference.
- Structurally reinforced for longevity.
- Insulated with high quality thermal materials to improve energy efficiency and heat retention.
- Large 530mm diameter internal cooking barrel.
- Easy installation or relocation.
- Slim, concealed operating system.
- Various external shapes and façade cladding options.

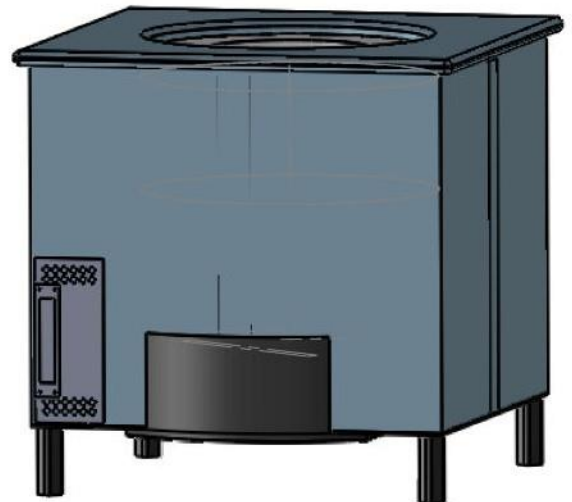

Sample image only, some details may vary

DRAFT ONLY

4kW WALL ELEMENTS

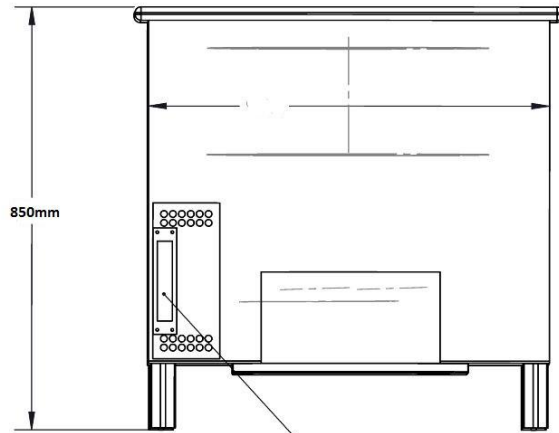

CONTROL CONSOLE

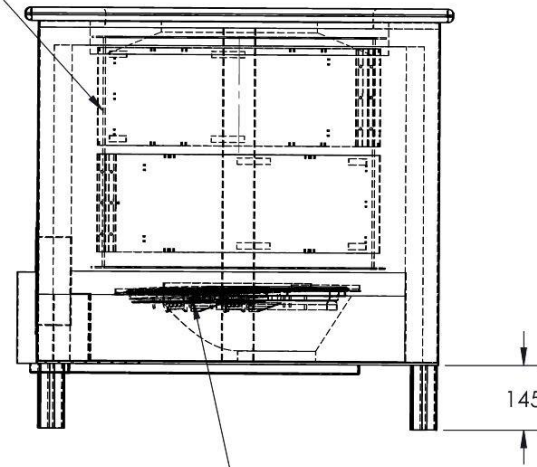

7kW BASE ELEMENTS

PHOENIX OVENS:
ELECTRIC TANDOOR:

POWER: 3PHASE with NEUTRAL
11kW

WEIGHT APPROX 500KG.

STEEL BOWL WITH CERAMIC COATING

CAST IRON BASE ELEMENTS

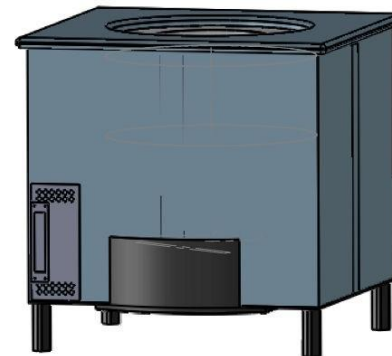
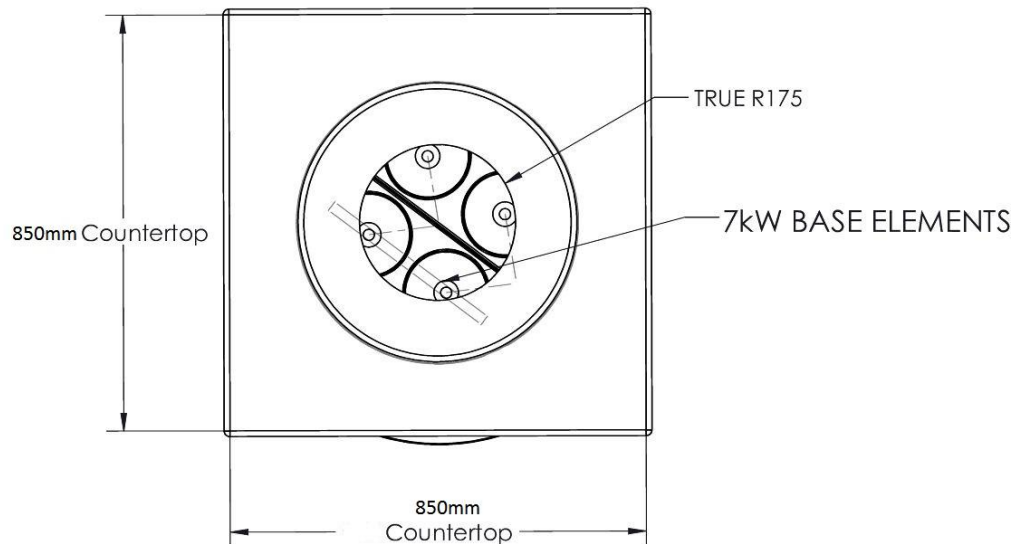

THE INFORMATION CONTAINED IN THIS DRAWING IS THE SOLE PROPERTY OF PHOENIX OVENS PTY.LTD.. ANY REPRODUCTION IN PART OR AS A WHOLE WITHOUT THE WRITTEN PERMISSION OF PHOENIX OVENS PTY.LTD. IS PROHIBITED.

PHOENIX OVENS. AUSTRALIA

TITLE:

DRAFT ONLY

DWG NO.

TANDOOR.01E

A3

DO NOT SCALE DRAWING

SHEET 1 OF 1

